

Technické údaje

Prevádzková kvapalina: vykurovací voda

Max. prevádzková teplota: 110°C

Max. prevádzkový tlak s ručnou hlavou: PN16

Max. prevádzkový tlak s termostatickou hlavou: 1 MPa (10 bar)

Max. diferenčný tlak s termostatickými hlavami: 0,14 MPa (1,4 bar), 3/8" - 1/2" - 3/4"
0,04 MPa (0,4 bar), 1"

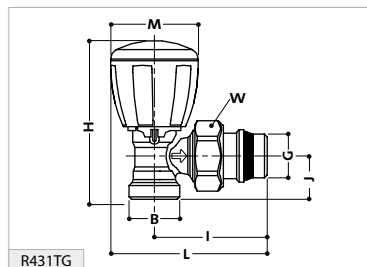

R431TG

Kód	GxB	H	I	J	L	M	W
R431X032	3/8"x 16	75	53	21	74	42	30
R431X033	1/2"x 16	75	53	21	74	42	30
R431X034	1/2"x 18	75	53	21	74	42	30

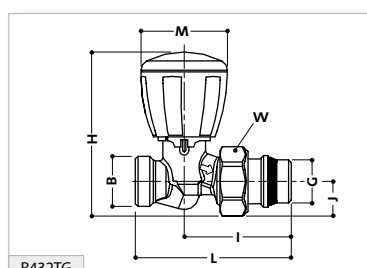

R432TG

Kód	GxB	H	I	J	L	M	W
R432X032	3/8"x 16	79	51	17	74	42	30
R432X033	1/2"x 16	79	51	17	75	42	30
R432X034	1/2"x 18	79	51	17	76	42	30

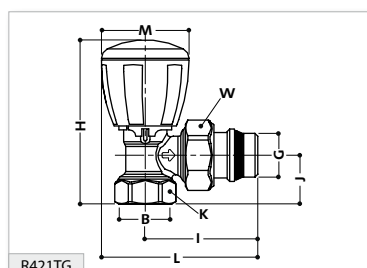

R421TG

Kód	GxB	H	I	J	K	L	M	W
R421X132	3/8"x 3/8"	74	51	20	22	72	42	27
R421X133	1/2"x 1/2"	78	53	23	26	74	42	30
R421X034	3/4"x 3/4"	79	60	25	32	81	42	38
R421X035	1x 1	97	72	31	39	94	42	46

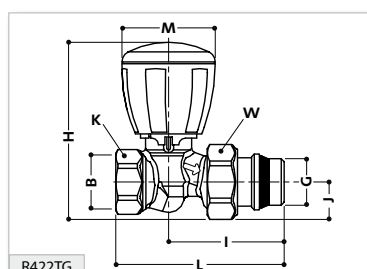

R422TG

Kód	GxB	H	I	J	K	L	M	W
R422X132	3/8"x 3/8"	77	51	15	22	71	42	27
R422X133	1/2"x 1/2"	79	51	17	26	82	42	30
R422X034	3/4"x 3/4"	83	55	21	32	81	42	38
R422X035	1x 1	95	64	26	39	105	42	46

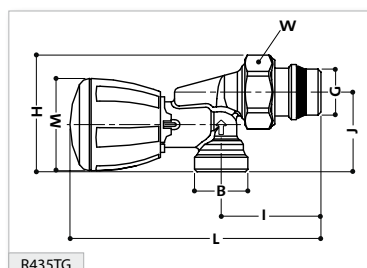

R435TG

Kód	GxB	H	I	J	K	L	M	W
R435X033	1/2"x 1/2"	53	45	36	25	113	42	30
R435X042	1/2"x 16	53	45	36	-	113	42	30
R435X043	1/2"x 18	53	45	37	-	113	42	30

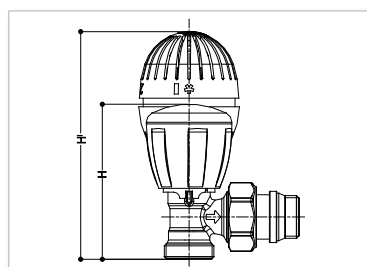

Rozmer s termostatickou hlavou

Kód	R470X001	R456X101	R452X101
H' - H	35	40	35



Prevádzková kvapalina: vykurovací voda

Max. prevádzková teplota: 110°C

Max. prevádzkový tlak s termostatickou hlavicoú: 1 MPa (10 bar)

Max. diferenčný tlak s termostatickými hlavicoúmi: 0,14 MPa (1,4 bar), 3/8" - 1/2" - 3/4"
0,04 MPa (0,4 bar), 1"

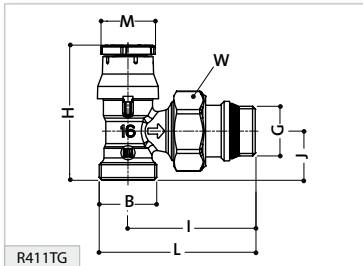

R411TG

Kód	GxB	H	I	J	L	M	W
R411X032	3/8"x16	56	53	21	66	23	30
R411X033	1/2"x 16	56	53	21	66	23	30
R411X034	1/2"x 18	56	53	21	66	23	30

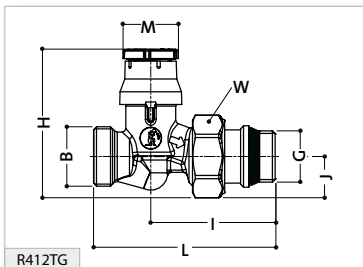

R412TG

Kód	GxB	H	I	J	L	M	W
R412X032	3/8"x16	60	51	17	74	23	30
R412X033	1/2"x 16	60	51	17	75	23	30
R412X034	1/2"x 18	60	51	17	76	23	30

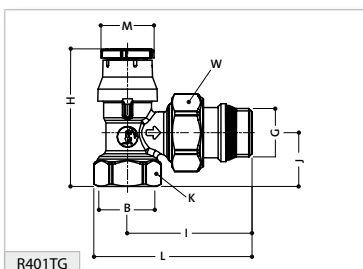

R401TG

Kód	GxB	H	I	J	K	L	M	W
R401X132	3/8"x 3/8"	55	51	20	22	64	23	27
R401X133	1/2"x 1/2"	59	53	23	26	68	23	30
R401X034	3/4"x 3/4"	60	60	25	32	78	23	38
R401X035	1"x 1"	78	72	31	39	94	23	46

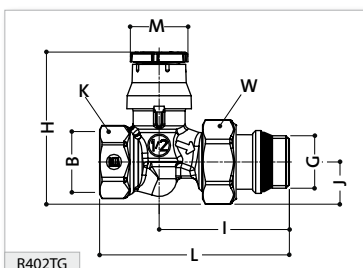

R402TG

Kód	GxB	H	I	J	K	L	M	W
R402X132	3/8"x 3/8"	58	54	15	22	76	23	27
R402X133	1/2"x 1/2"	60	55	17	26	82	23	30
R402X034	3/4"x 3/4"	64	55	21	32	81	23	38
R402X035	1"x 1"	76	64	26	39	105	23	46

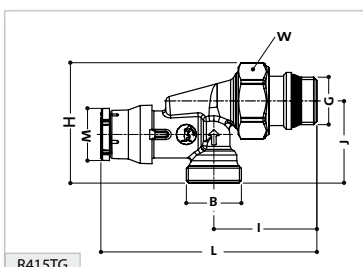

R415TG

Kód	GxB	H	I	J	K	L	M	W
R415X033	1/2"x 1/2"	53	45	36	25	94	23	30
R415X042	1/2"x 16	53	45	36	-	94	23	30
R415X043	1/2"x 18	53	45	37	-	94	23	30

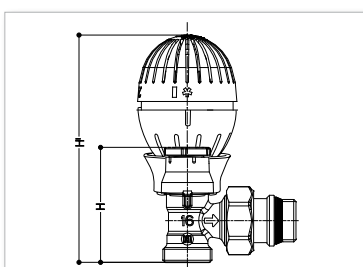

Rozmer s termostatickou hlavicoú

Kód	R470X001	R456X101	R452X101
H-H	54	59	54



• Technické údaje

Prevádzková kvapalina: vykurovací voda

Max. prevádzková teplota: 110°C

Max. prevádzkový tlak s ručnou hlavou: PN16

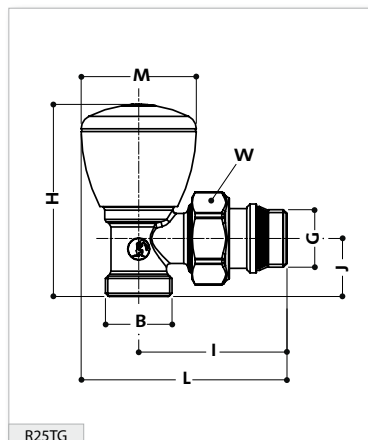

R25TG

Kód	GxB	H	I	J	L	M	W
R25X032	3/8" x 16	69	53	21	74	42	30
R25X033	1/2" x 16	69	53	21	74	42	30
R25X034	1/2" x 18	73	54	24	75	42	30
R25X035	3/4" x 18	79	60	24	84	49	38
R25X036	3/4" x 22	79	60	24	84	49	38

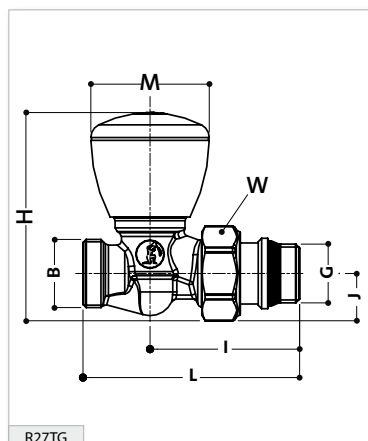

R27TG

Kód	GxB	H	I	J	L	M	W
R27X032	3/8" x 16	73	52	17	75	42	30
R27X033	1/2" x 16	73	52	17	76	42	30
R27X034	1/2" x 18	73	52	17	77	42	30
R27X035	3/4" x 18	87	55	21	81	49	38
R27X036	3/4" x 22	87	55	21	91	49	38

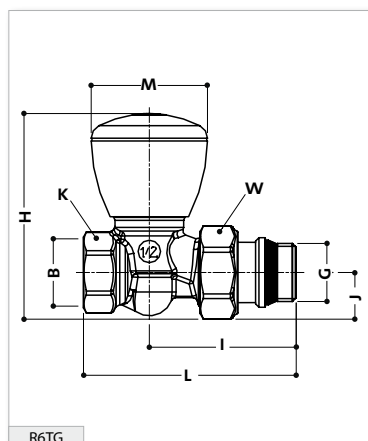

R6TG

Kód	GxB	H	I	J	K	L	M	W
R5X032	3/8" x 3/8"	65	50	19	22	71	42	27
R5X033	1/2" x 1/2"	70	53	21	26	74	42	30
R5X034	3/4" x 3/4"	79	60	23	32	84	49	38
R5X035	1" x 1"	87	68	30	39	92	49	46
R5X036	1 1/4" x 1 1/4"	92	81	33	49	110	59	53

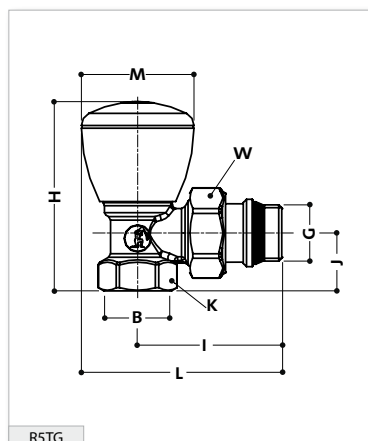

R5TG

Kód	GxB	H	I	J	K	L	M	W
R6X032	3/8" x 3/8"	69	51	15	22	72	42	27
R6X033	1/2" x 1/2"	73	52	17	26	76	42	30
R6X034	3/4" x 3/4"	86	55	21	32	81	49	38
R6X035	1" x 1"	93	69	26	39	106	49	46
R6X036	1 1/4" x 1 1/4"	97	84	30	49	135	59	53



Prevádzková kvapalina: vykurovací voda
 Max. prevádzková teplota: 110°C
 Max. prevádzkový tlak s ručnou hlavou: PN16

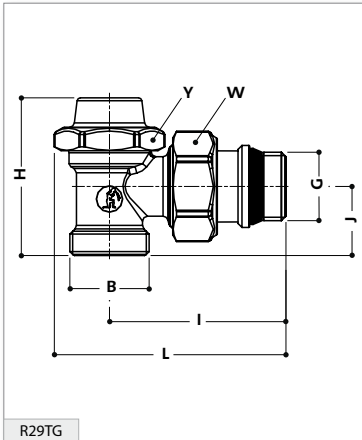

R29TG

Kód	GxB	H	I	J	L	Y	W
R29X032	3/8" x 16	48	53	21	70	30	30
R29X033	1/2" x 16	48	53	21	70	30	30
R29X034	1/2" x 18	51	54	24	71	30	30
R29X035	3/4" x 18	54	60	24	79	38	35
R29X036	3/4" x 22	61	60	31	79	38	35

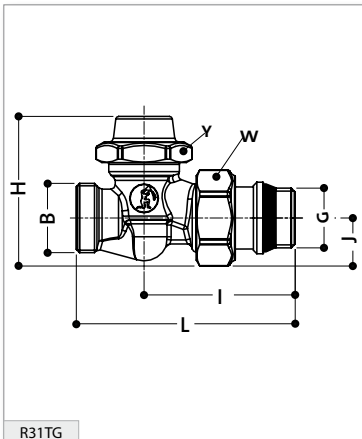

R31TG

Kód	GxB	H	I	J	L	Y	W
R31X032	3/8" x 16	52	52	17	75	30	30
R31X033	1/2" x 16	52	52	17	75	30	30
R31X034	1/2" x 18	52	52	17	77	30	30
R31X035	3/4" x 18	62	54	21	81	38	35
R31X036	3/4" x 22	62	54	21	85	38	35

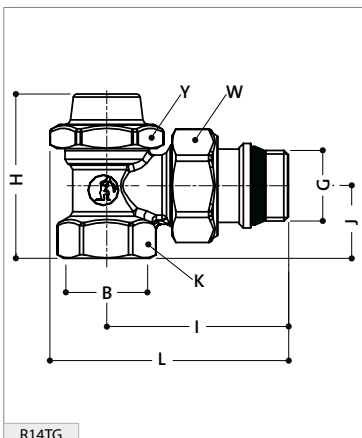

R14TG

Kód	GxB	H	I	J	K	L	Y	W
R14X032	3/8" x 3/8"	44	50	19	22	65	27	27
R14X033	1/2" x 1/2"	48	53	21	26	70	30	30
R14X034	3/4" x 3/4"	54	60	23	32	79	38	35
R14X035	1" x 1"	72	68	30	39	90	46	40
R14X036	1" 1/4 x 1" 1/4	80	80	34	49	108	53	46

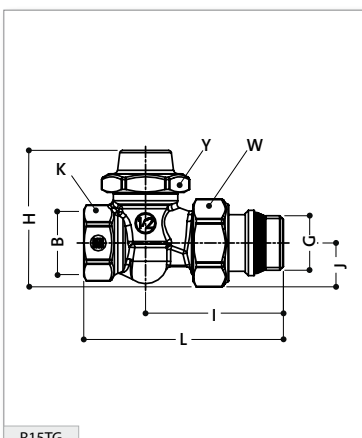

R15TG

Kód	GxB	H	I	J	K	L	Y	W
R15X032	3/8" x 3/8"	48	51	15	22	71	27	27
R15X033	1/2" x 1/2"	52	52	17	26	76	30	30
R15X034	3/4" x 3/4"	62	55	21	32	81	38	35
R15X035	1" x 1"	78	69	26	39	106	46	40
R15X036	1" 1/4 x 1" 1/4	86	78	30	49	119	53	46

